

CANDIDATE
NAME

CENTRE
NUMBER

--	--	--	--

CANDIDATE
NUMBER

--	--	--	--



PHYSICS

9702/35

Paper 3 Advanced Practical Skills 1

October/November 2015

2 hours

Candidates answer on the Question Paper.

Additional Materials: As listed in the Confidential Instructions.

READ THESE INSTRUCTIONS FIRST

Write your Centre number, candidate number and name on all the work you hand in.
Write in dark blue or black pen.
You may use an HB pencil for any diagrams or graphs.
Do not use staples, paper clips, glue or correction fluid.
DO NOT WRITE IN ANY BARCODES.

Answer **both** questions.
You will be allowed to work with the apparatus for a maximum of one hour for each question.
You are expected to record all your observations as soon as these observations are made, and to plan the presentation of the records so that it is not necessary to make a fair copy of them.
You are reminded of the need for good English and clear presentation in your answers.

Electronic calculators may be used.
You may lose marks if you do not show your working or if you do not use appropriate units.

Additional answer paper and graph paper should be used only if it becomes necessary to do so.

At the end of the examination, fasten all your work securely together.
The number of marks is given in brackets [] at the end of each question or part question.

For Examiner's Use	
1	
2	
Total	

This document consists of **14** printed pages and **2** blank pages.

You may not need to use all of the materials provided.

- 1 In this experiment, you will investigate how the potential difference across a resistor changes as the resistance of the circuit is changed.

(a) (i) Set up the circuit shown in Fig. 1.1.

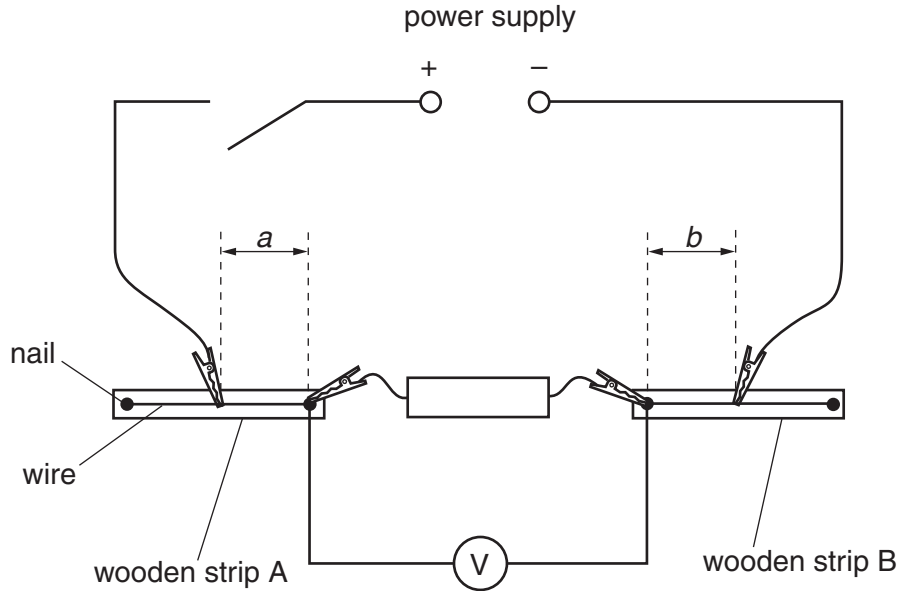

Fig. 1.1

The two crocodile clips attached to the wires on the wooden strips should be approximately half-way along each of the wires.

(ii) Measure and record the lengths a and b .

$a =$

$b =$

(iii) Calculate the value of C where $C = a + b$.

$C =$

(iv) Close the switch.

(v) Record the voltmeter reading V .

$V =$

(vi) Open the switch.

(b) (i) Change the value of a . Measure and record this value of a .

$a = \dots\dots\dots$ [1]

(ii) Calculate the new value of b using $b = C - a$.

$b = \dots\dots\dots$

(iii) Change b to the value shown in (b)(ii).

(iv) Close the switch.

(v) Record the voltmeter reading V .

$V = \dots\dots\dots$ [1]

(vi) Open the switch.

(c) Repeat (b) until you have six sets of readings of a , b and V .

Include values of $\frac{1}{V}$ in your table.

[10]

(d) (i) Plot a graph of $\frac{1}{V}$ on the y -axis against b on the x -axis.

[3]

(ii) Draw the straight line of best fit.

[1]

(iii) Determine the gradient and y -intercept of this line.

gradient =

y -intercept =

[2]

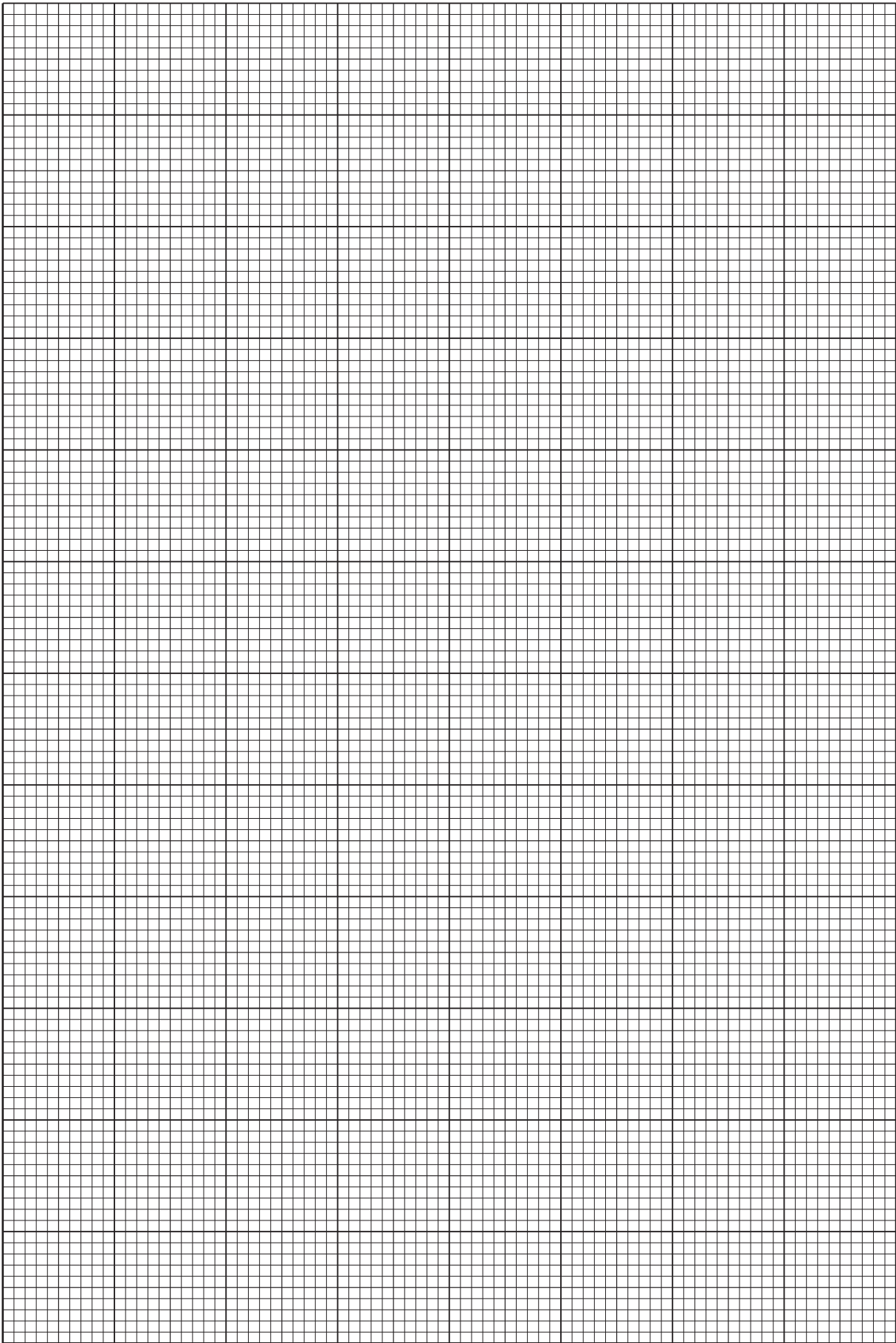

(e) The quantities V and b are related by the equation

$$\frac{1}{V} = Pb + Q$$

where P and Q are constants.

Using your answers in (d)(iii), determine values for P and Q .
Give appropriate units.

$P =$

$Q =$

[2]

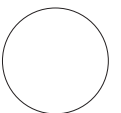

You may not need to use all of the materials provided.

2 In this experiment, you will investigate the motion of a magnetised object in a magnetic field.

(a) You have been provided with a nail and two magnets.

Hold the head of the nail.

Move one of the magnets as shown by the dotted path in Fig. 2.1.

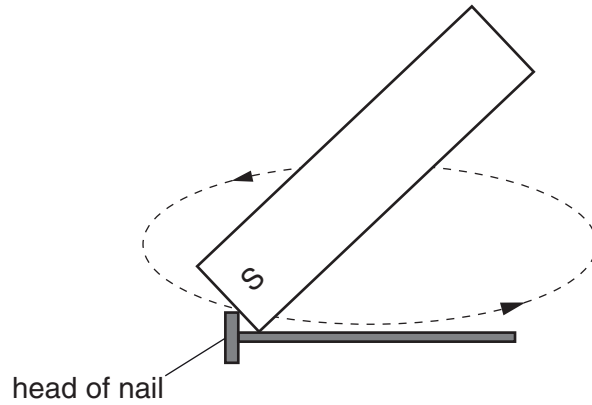

Fig. 2.1

The S pole of the magnet should remain in contact with the nail until it reaches the end of the nail. At the end of the nail, lift the magnet above the nail and back to the head. Repeat 10 times.

The nail should not touch a magnet during the remainder of the experiment. If it does, you should re-magnetise the nail by repeating (a).

(b) (i) Place the sheet of paper flat on the bench as shown in Fig. 2.2.

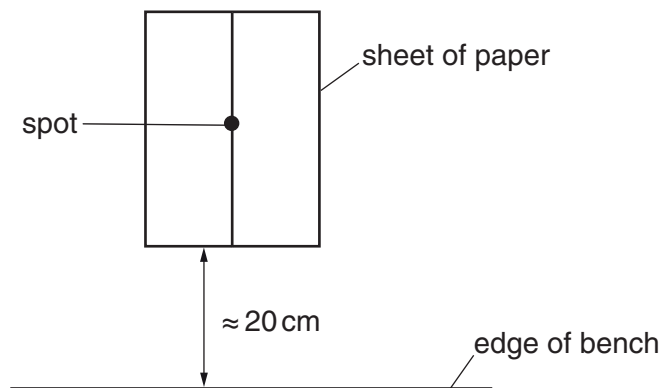

Fig. 2.2

- (ii) Set up the apparatus as shown in Fig. 2.3.

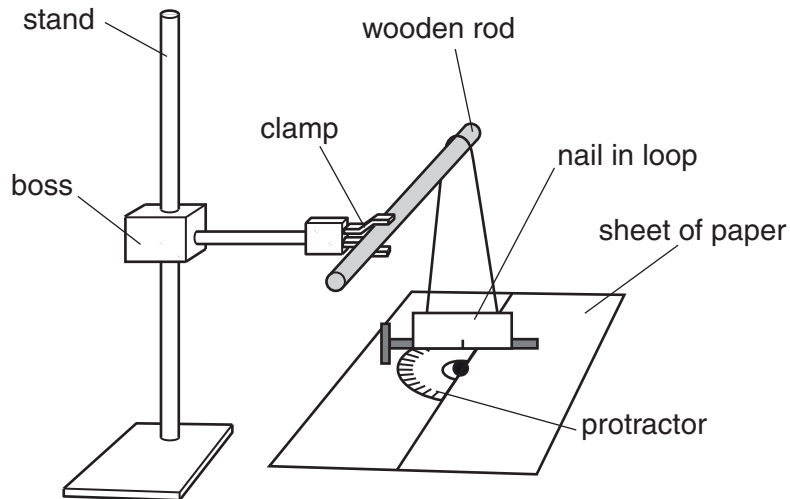

Fig. 2.3

Place the protractor on the line with its centre over the spot.

Align the rod so that the rod is directly above and parallel to the line on the sheet of paper.

Place the nail in the paper loop.

Suspend the loop from the rod. The nail will be perpendicular to the line on the sheet of paper.

The nail should be just above the protractor with the mark on the loop above the spot on the line. The loop should be free to rotate.

- (iii) With the apparatus set up as shown in Fig. 2.3, position the magnets on the sheet of paper as shown in Fig. 2.4.

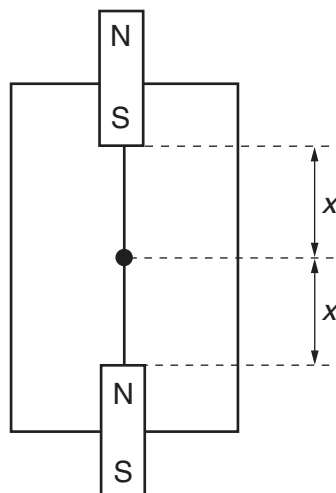

Fig. 2.4

Move the magnets along the line until the nail rotates through approximately 45° . The magnets should each be the same distance x from the spot and **should remain in these positions throughout the experiment.**

(iv) Measure and record x .

$x = \dots\dots\dots$ [1]

(c) (i) Without removing the loop and nail, move the wooden rod so that the rod makes an angle θ of approximately 30° to the line on the sheet of paper as shown in Fig. 2.5.

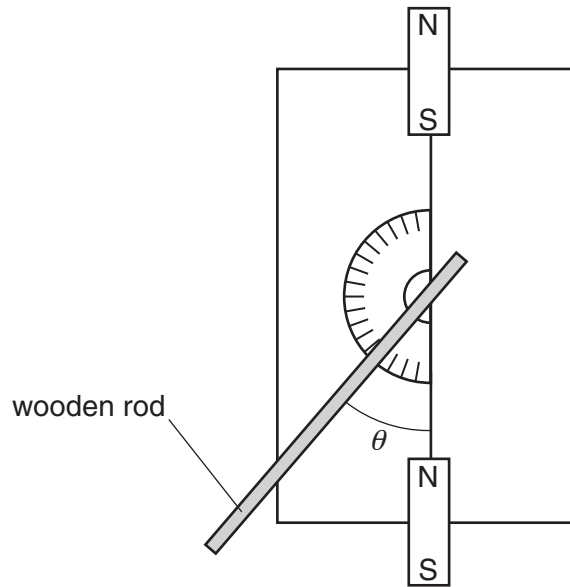

Fig. 2.5

The mark on the loop should be above the spot.

Measure and record θ .

$\theta = \dots\dots\dots^\circ$ [1]

(ii) Estimate the percentage uncertainty in your value of θ .

percentage uncertainty = $\dots\dots\dots$ [1]

(iii) Calculate $\cos^2\left(\frac{\theta}{2}\right)$.

$\cos^2\left(\frac{\theta}{2}\right) = \dots\dots\dots [1]$

(iv) Justify the number of significant figures that you have given for your value of $\cos^2\left(\frac{\theta}{2}\right)$.

.....

 [1]

(d) (i) Rotate the nail and loop through approximately 45° . Release the nail. It should complete a cycle as shown in Fig. 2.6.

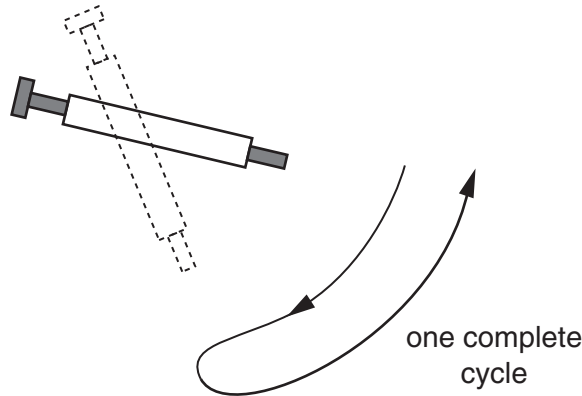

Fig. 2.6

(ii) The time taken for one complete cycle is T .

By timing several of these complete cycles, determine an accurate value for T .

$T = \dots\dots\dots [2]$

- (e) (i) Remove the nail from the loop and replace it in the loop **the other way round**.
 (ii) Repeat (d) to obtain the time T taken for one complete cycle.

$T = \dots\dots\dots$

- (iii) You have two values of T from (d)(ii) and (e)(ii).

One of your values of T will be shorter than the other. This is T_1 . The other value is T_2 . Record your values of T_1 and T_2 below.

shorter time $T_1 = \dots\dots\dots$

longer time $T_2 = \dots\dots\dots$

- (iv) Calculate $\frac{T_1}{T_2}$.

$\frac{T_1}{T_2} = \dots\dots\dots$

(f) Repeat (c)(i), (c)(iii), (d) and (e) with the wooden rod at an angle θ of approximately 60° .

$\theta = \dots\dots\dots^\circ$

$\cos^2\left(\frac{\theta}{2}\right) = \dots\dots\dots$

$T = \dots\dots\dots$

with nail other way round, $T = \dots\dots\dots$

shorter time $T_1 = \dots\dots\dots$

longer time $T_2 = \dots\dots\dots$

$\frac{T_1}{T_2} = \dots\dots\dots$

[3]

(g) It is suggested that the relationship between T_1 , T_2 and θ is

$$\frac{T_1}{T_2} = k \cos^2\left(\frac{\theta}{2}\right)$$

where k is a constant.

(i) Using your data, calculate two values of k .

first value of $k = \dots\dots\dots$

second value of $k = \dots\dots\dots$

[1]

(ii) Explain whether your results support the suggested relationship.

.....

.....

.....

.....

[1]

(h) (i) Describe four sources of uncertainty or limitations of the procedure for this experiment.

1.

.....

2.

.....

3.

.....

4.

.....

[4]



(ii) Describe four improvements that could be made to this experiment. You may suggest the use of other apparatus or different procedures.

1.

.....

2.

.....

3.

.....

4.

.....

[4]

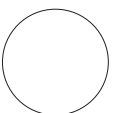

BLANK PAGE

Permission to reproduce items where third-party owned material protected by copyright is included has been sought and cleared where possible. Every reasonable effort has been made by the publisher (UCLES) to trace copyright holders, but if any items requiring clearance have unwittingly been included, the publisher will be pleased to make amends at the earliest possible opportunity.

To avoid the issue of disclosure of answer-related information to candidates, all copyright acknowledgements are reproduced online in the Cambridge International Examinations Copyright Acknowledgements Booklet. This is produced for each series of examinations and is freely available to download at www.cie.org.uk after the live examination series.

Cambridge International Examinations is part of the Cambridge Assessment Group. Cambridge Assessment is the brand name of University of Cambridge Local Examinations Syndicate (UCLES), which is itself a department of the University of Cambridge.