

Physics (0625) - IGCSE



<https://keddy-edtech.org/>

Contents

FULL FORMULA SHEET

1 Motion, forces and energy

1.1 Physical quantities and measurement techniques

1.2 Motion

1.3 Mass and weight

1.4 Density

1.5 Forces

1.6 Momentum

1.7 Energy, work and power

1.8 Pressure

2 Thermal physics

2.1 Kinetic particle model of matter

2.2 Thermal properties and temperature

2.3 Transfer of thermal energy

3 Waves

3.1 General properties of waves

3.2 Light

3.3 Electromagnetic spectrum

3.4 Sound

4 Electricity and magnetism

4.1 Simple phenomena of magnetism

4.2 Electrical quantities

4.3 Electric circuits

4.4 Electrical safety

4.5 Electromagnetic effects

5 Nuclear physics

5.1 The nuclear model of the atom

5.2 Radioactivity

6 Space physics

6.1 Earth and the Solar System

6.2 Stars and the Universe

1 Motion, forces and energy

1.1 Physical quantities and measurement techniques

Measuring equipment:

- Rulers: to find length
- Measuring cylinders: to find a volume

Oscillation of a pendulum: To find an accurate measurement, measure multiple oscillations and find the average.

Scalar	Vector
Has magnitude only. E.g. distance, speed, time, mass, energy and temperature.	Has magnitude and direction. E.g. force, weight, velocity, acceleration, momentum, electric field strength and gravitational field strength.

Finding resultant of two vectors at right angles:

- Vectors can be added together to produce a **resultant vector**.
- If two vectors point in the **same direction**, the resultant vector will also have the same directions and its value will be the result of adding the magnitudes of the two original vectors together.
- If two vectors point in **opposite directions** then subtract the magnitude of one of the vectors from the other one. The direction of the resultant will be the same as the larger of the two original vectors.
- If the two vectors point in completely **different directions**, then the value of the resultant vector can be found graphically (Draw an arrow for the first vector. Draw a second arrow for the second vector at the head of the first arrow. Draw an arrow going from the tail of the first vector to the tip of the second vector to find the resultant vector.

1.2 Motion

Speed – Distance travelled per unit time

$$v = \frac{s}{t} \quad \text{average speed} = \frac{\text{total distance travelled}}{\text{total time taken}}$$

Velocity – speed in a given direction

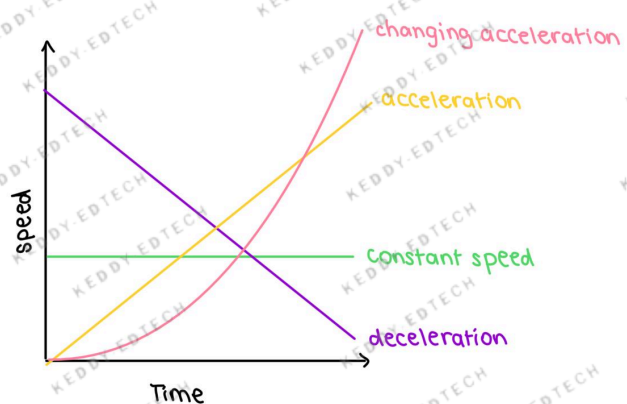
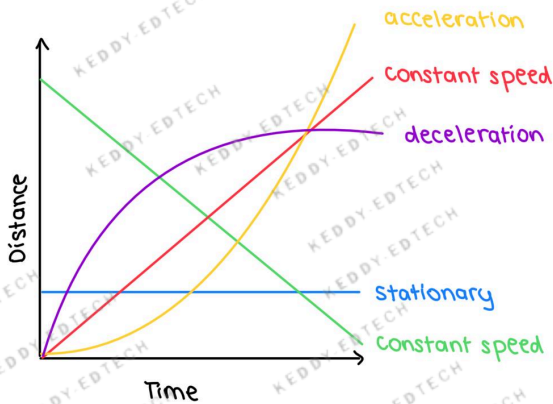

Speed = gradient from distance–time graph.

Distance travelled = area under a speed–time graph.

Acceleration = gradient of a speed–time graph.

The acceleration of free fall for an object near to the surface of the Earth is constant and is approximately 9.8m/s^2 .

Acceleration – Change in velocity per unit time.

Deceleration – Negative acceleration.

$$a = \frac{\Delta v}{\Delta t}$$

Without air resistance, objects fall at a constant speed (9.8m/s^2).

With air resistance, objects accelerate until terminal velocity.

Terminal velocity - The speed of a falling object where there are no resultant forces acting.

When terminal velocity is reached, air resistance and weight become equal, thus the velocity of the object is constant and acceleration is 0.

1.3 Mass and weight

Mass – A measure of the quantity of matter in an object at rest.

Weight – A gravitational **force** on an object that has mass. Weight is the effect of a gravitational field on a mass.

Gravitational field strength – Force per unit mass.

$$g = \frac{W}{m}$$

Gravitational field strength is equivalent to the acceleration of free fall.

A balance can be used to compare weights and masses.

1.4 Density

Density – Mass per unit volume.

$$\rho = \frac{m}{V}$$

How to find volume of irregular solids (displacement method):

1. Measure the initial volume of liquid.
2. Submerge the solid inside the liquid.
3. Take the final reading of the liquid
4. Find the difference in volume.
5. Difference in volume = volume of solid.

How to find the density of liquids & solids:

1. Find out the volume. For liquid, use a measuring cylinder. For solids, use the displacement method, or use the equation height * width * length
2. Find out the mass, by using a beam balance or an electronic balance.
3. Calculate density with the equation. $\rho = m/v$

Float or sink?

- A substance (solid or liquid) which is less dense than water will float.

1.5 Forces

1.5.1 Effects of forces

Effects of forces:

- Changes size of object
- Changes shape
- Changes the speed of motion
- Changes direction of motion

Load-extension practical:

1. Take a spring and suspend it from a clamp & stand.
2. Attach a ruler to the clamp.
3. Add a pointer for more accurate readings to prevent parallax error.
4. Measure initial position of pointer.
5. Add 100g masses.
6. Continue until limit of proportionality and measure the position of pointer each time.
7. Repeat to get accurate results.

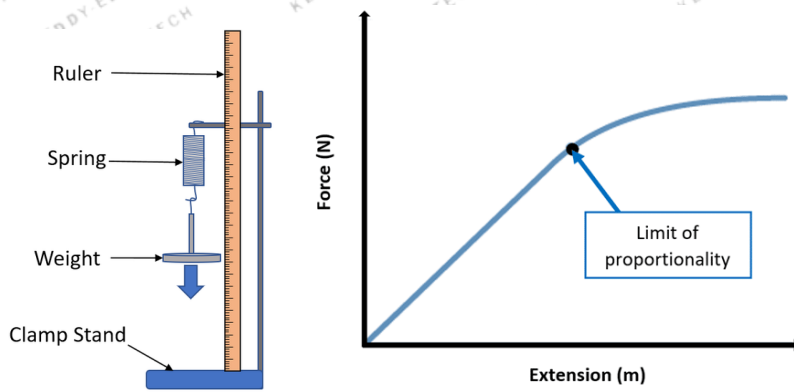

Resultant forces acting along the same straight line:

Applied Force	Resultant force

An object either remains at rest or continues in a straight line at constant speed unless acted on by a resultant force.

Friction – The force between two surfaces that may impede motion and produce heat.

Friction (drag) acts on an object moving through a liquid.

Friction (drag) acts on an object moving through a gas (e.g. air resistance).

Spring constant – Force per unit extension

$$k = \frac{F}{x}$$

Limit of proportionality – The maximum force that can be applied to a spring so that it can still return to its original length/shape when the force is removed.

When the limit of proportionality is exceeded, the spring will no longer bounce back to its original shape after the force is removed.

$$F = ma$$

Motion in a circular path due to a force perpendicular to the motion:

- Speed increases if force increases, with mass and radius constant.
- Radius decreases if force increases, with mass and speed constant.
- An increased mass requires an increased force to keep speed and radius constant.

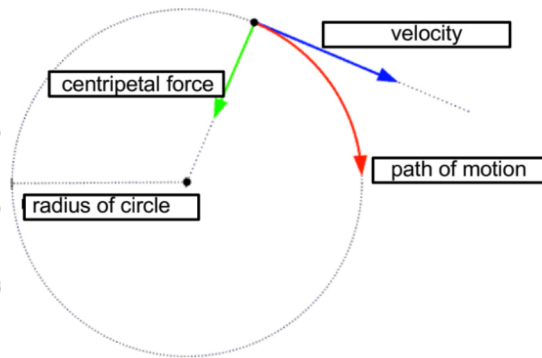

1.5.2 Turning effect of forces

Moment of a force – A measure of a turning effect of a force around a pivot.

Moment = force \times perpendicular distance from the pivot

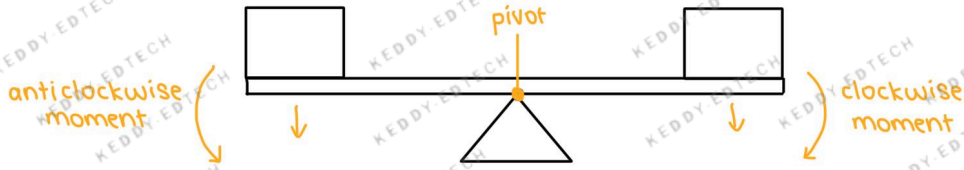

Everyday applications: A door opening around a fixed hinge, seesaws, scissors.

For equilibrium there must be: no resultant force, no resultant moment.

Opposing moments are balanced when: sum of the clockwise = sum of the anti-clockwise.

Opposing forces are balanced when: sum of upward forces = sum of downward forces.

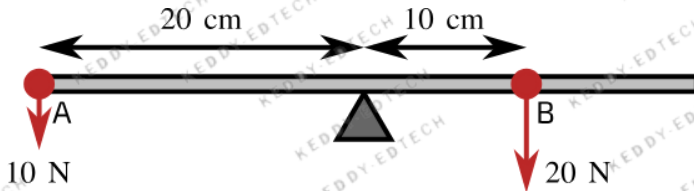

Demonstrating equilibrium:

1. Take an object (e.g. a beam) and replace the supports with newton metres.
2. The forces acting on the beam can be found by measuring using newton meters or measuring the masses (then calculating the weights) of the beam.
3. The distance of each force from the end of the ruler can then be measured.
4. The moment of each force about the end of the ruler to be calculated.
5. The sum of clockwise moments = the sum of anticlockwise moments.

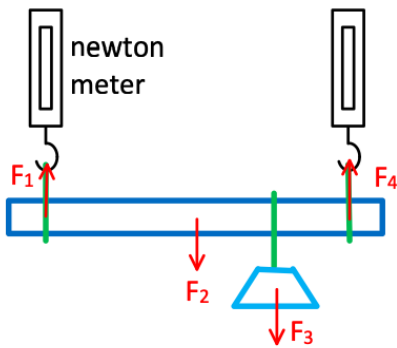

1.5.3 Centre of gravity

Centre of gravity – The point an object's weight will act through.

Determine centre of gravity:

1. Hang the irregular shape with a pin and a thread of plumb line.

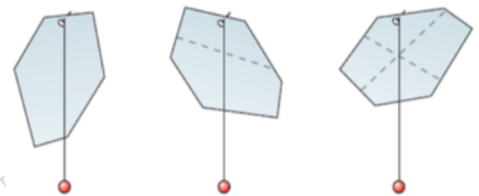

2. Draw a line based on the thread.
3. The point where the lines intersect is the centre of gravity.

For an object to be stable it should have a low centre of gravity and a wide base

1.6 Momentum

Momentum = mass × velocity

$$p = mv$$

Impulse = force × time for which force acts = change in momentum

$$\text{impulse} = F\Delta t = \Delta(mv)$$

Momentum is a vector quantity (has magnitude AND direction), so if velocities are in opposite directions we must take this into account in our calculations (negative value = opposite direction).

Principle of the conservation of momentum:

- In an isolated system, momentum remains constant.
- When objects collide, momentum is conserved.
- Total momentum before the collision = Total momentum after.
- Kinetic energy can change.

Resultant force – The change in momentum per unit time.

$$F = \frac{\Delta p}{\Delta t}$$

1.7 Energy, work and power

1.7.1 Energy

Types of energy:

- Heat
- Light
- Sound
- Kinetic
- Electric
- Chemical
- Gravitational potential
- Elastic
- Nuclear
- Electrostatic
- Internal (thermal)

Energy is transferred between stores during events and processes.

Examples:

Ball lifted to a height above the ground: Kinetic energy -> gravitational potential energy

Ball falls: Gravitational potential energy -> kinetic energy

Bird flies through air: Chemical energy -> kinetic energy + thermal energy

The Law of Conservation of Energy - Energy can be changed (transformed) from one type to another, but it can never be made or destroyed.

Gravitational potential energy:

$$\Delta E_p = mg\Delta h$$

Kinetic energy:

$$E_k = \frac{1}{2}mv^2$$

Sankey diagram:

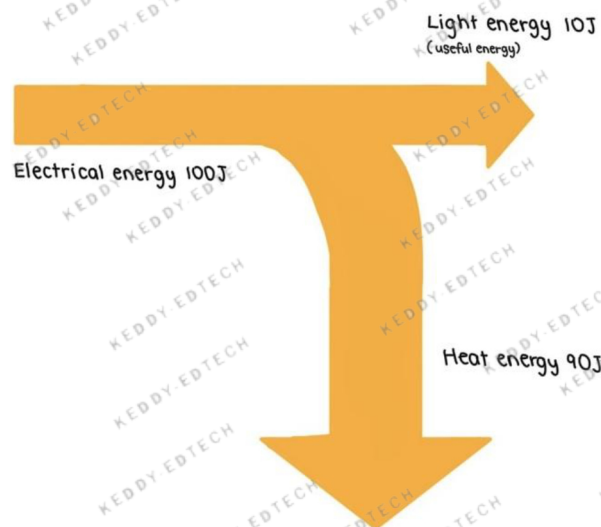

1.7.2 Work

Mechanical or electrical work done is equal to the energy transferred.

$$W = Fd = \Delta E$$

1.7.3 Energy resources

Energy and electrical power can be generated from:

- Chemical energy stored in fossil fuels
- Chemical energy stored in biofuels
- Water, from energy stored in waves, tides, and water behind hydroelectric dams.
- Geothermal resources
- Nuclear fuel
- Light from the Sun to generate electrical power (solar cells)
- Infrared and other electromagnetic waves from the Sun to heat water (solar panels) and be the source of wind energy

Tidal energy - Energy stored in tidal currents

Wind energy - Energy stored from wind movement

Wave energy - Energy stored in waves movement

Geothermal energy - Energy stored from the heat of the Earth's core

Solar energy - Energy stored in sunlight

Biofuels - a fuel derived immediately from living matter

Renewable energy - Sources of energy that can be replenish

Non-renewable energy - Sources of energy that cannot be replenish

Fossil fuels	
Advantages	Disadvantages
Abundant Reliable	Non renewable Causes pollution & greenhouse gases

Biofuels	
Advantages	Disadvantages
Renewable Abundant Reliable	Causes pollution & greenhouse gases

Tidal energy	
Advantages	Disadvantages
Renewable No pollution Reliable	May damage habitats

Hydroelectric energy	
Advantages	Disadvantages
Renewable No pollution Abundant Reliable	Large area needed Destroys wildlife habitats Could cause flooding

Geothermal energy	
Advantages	Disadvantages
Renewable Abundant Reliable No harmful pollution	Release of greenhouse gas underground Surface instability

Nuclear fuels	
Advantages	Disadvantages
No pollution Reliable	Non renewable Radioactive waste produced Risk of explosion

Solar energy	
Advantages	Disadvantages
Renewable No pollution Abundant	Not reliable

Wind energy	
Advantages	Disadvantages
Renewable No pollution Abundant	Not reliable Noisy

Efficiency of energy transfer – how much energy is transferred to do something useful.

Radiation from the Sun is the main source of energy for all our energy resources except geothermal, nuclear and tidal.

Energy is released by nuclear fusion in the Sun.

Research is being carried out to investigate how energy released by nuclear fusion can be used to produce electrical energy on a large scale.

$$\text{efficiency} = \frac{(\text{useful energy output})}{(\text{total energy input})} (\times 100\%) \quad \text{efficiency} = \frac{(\text{useful power output})}{(\text{total power input})} (\times 100\%)$$

1.7.4 Power

Power – Work done per unit time. OR energy transferred per unit time.

$$P = \frac{W}{t} \quad p = \frac{\Delta E}{t}$$

1.8 Pressure

Pressure – Force per unit area

$$p = \frac{F}{A}$$

The larger the force, the more pressure
The smaller the area, the more pressure

Everyday applications:

- A sofa has more pressure than an empty box.
- Heels have more pressure than flats on the floor.

Pressure in fluids / liquids

- Pressure increases with depth.
- Pressure acts in all directions. For a submarine this means that pressure is being exerted equally on all parts of the hull.
- Pressure increases as density increases.
- Pressure doesn't depend on the shape of container. The pressure at any particular depth is the same whatever the shape or width of the container.

Air Pressure

- Air pressure in the atmosphere acts in all directions.
- Air pressure gets less as you rise up through the atmosphere. The atmosphere is denser at lower levels.
- Measured using a barometer.

$$\Delta p = \rho g \Delta h$$

2 Thermal physics

2.1 The Kinetic Particle Model of Matter

	Solid	Liquid	Gas
Forces between molecules	Balanced forces which hold molecules in fixed positions.	Forces as strong as those in solid. Molecules not held in fixed position, move among one another.	Negligible. Only at moments of collision, the intermolecular forces act.
Distance between molecules	Close together in a regular pattern.	Not arranged in a regular pattern, slightly further apart than in solid.	Far apart Mainly empty space between molecules.
Motion of molecules	Vibrate about fixed positions. Alternately attracting & repelling one another.	Vibrate to & fro Alternately attracting & repelling one another.	Move randomly with high speed, colliding with one another and with the walls of the containers.
Compression	Cannot be compressed.	Cannot be compressed.	Can be easily compressed.

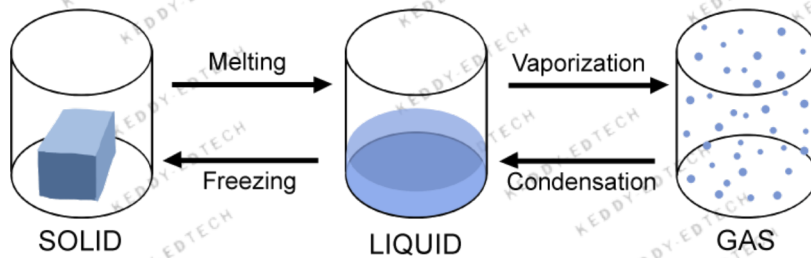

As temperature increases: Surrounding air particles move faster and hit the particles more frequently and harder. Thermal energy is transferred to the molecules and the molecules gain kinetic energy causing molecules to move faster & more collisions.

The lowest possible temperature (-273°C), known as absolute zero, is where the particles have least kinetic energy.

Pressure of gas is caused by collision of molecules with walls of the container.

The magnitude of pressure is related to how hard/often the molecules strike the wall.

Pressure increases when: volume decreases OR temperature increase

Brownian Motion - Random collisions between the microscopic particles in a suspension and the particles of the gas or liquid. It is due to the instantaneous imbalance in the combined forces exerted by collisions of the particle with the much smaller liquid molecules surrounding it. This is evidence for the kinetic particle model of matter.

E.g. smoke particles moving in the air due to the bombardment of smaller microscopic air particles

$$T \text{ (in K)} = \theta \text{ (in } ^\circ\text{C)} + 273$$

$pV = \text{constant}$ for a fixed mass of gas at constant temperature.

2.2 Thermal Properties & temperature

When materials are heated, they expand.

Temperature increases, leading to increase in kinetic energy.

This expansion happens because the molecules move/vibrate faster, which causes them to move further apart.

This separation of the molecules makes the substance bigger.

Molecules itself do not expand, the space in between them expands.

	Solid	Liquid	Gas
When heated (at constant pressure)	Molecules gain energy & vibrate more. Expands slightly	Molecules vibrate & move about more vigorously Expands more than solids	Move even more randomly at higher speed, colliding with one another and with the walls of containers. Expands significantly

Applications: Thermometers, Temperature-activated switches

Consequences:

Buckling - The expansion of solid materials (metal railway tracks, road surfaces, bridges) can cause them to buckle if they get too hot. Gaps built in to create space for the expansion to happen without causing damage.

Specific heat capacity – The energy required per unit mass per unit temperature increases.

$$\Delta E = mc\Delta\theta$$

Change in thermal energy (J) = mass (kg) x specific heat capacity (J/kg°C) x change in temperature (°C)

Apparatus to measure heat capacity of a solid: thermometer, heater, power supply, ammeter, voltmeter, solid.

Melting and boiling occurs when particles gain energy, without a change in temperature.

Condensation and solidification occurs when particles lose energy.

Evaporation occurs when energetic particles escape from the surface of a liquid. Evaporation causes cooling of a liquid.

Boiling	Evaporating
Occurs throughout the liquid. Happens at the boiling point of the liquid.	Occurs at the surface of a liquid. Happens at any temperature.

Pure water melting point = 0°C, boiling point = 100°C

Evaporation increases when: temperature increases, surface area increases, air movement over the surface increases.

2.3 Transfer of thermal energy

2.3.1 Conduction

Movement in thermal conduction of all solids:

- Atomic/molecular lattice vibrations
- Movement of free (delocalised) electrons in metallic conductors.

Conduction is the transfer of thermal energy between substances (solids).

Thermal conduction is bad in gases and most liquids, because physical contact of neighbouring molecules interacting & vibrating against each other is needed.

There are many solids that conduct thermal energy better than thermal insulators. But some thermal conductors work better than others.

2.3.2 Convection

Convection is an important method of thermal energy transfer in liquids and gases.

As temperature increases from convection, the liquid/gas becomes less dense, causing it to rise. As the liquid/gas rises it cools down and becomes more dense, causing it to sink. This is known as a convection current, the movement of liquids/gases in a substance.

2.3.3 Radiation

Thermal radiation is infrared radiation. All objects emit this radiation.

Thermal energy transfer by thermal radiation does not require a medium.

Dull, black surfaces absorb/emit better. Shiny, white surfaces absorb/emit poorly.

For an object to be at a constant temperature it needs to transfer energy away from the object at the same rate that it receives energy.

If the rate at which it receives energy is less than the rate at which it transfers energy away from the object, temperature decreases.

The temperature of the Earth is affected by factors controlling the balance between incoming radiation and radiation emitted from the Earth's surface.

Radiation increases when: temperature increases, surface area increases.

2.3.4 Consequences of thermal energy transfer

Consequences of thermal energy transfer:

- Heating objects such as kitchen pans
- Heating a room by convection

3 Waves

3.1 General properties of waves

Waves transfer energy without transferring matter.

Wave – A repeating disturbance or movement that transfers energy through matter or space.

Features of a wave: wavefront, wavelength, frequency, crest, trough, amplitude, wave speed.

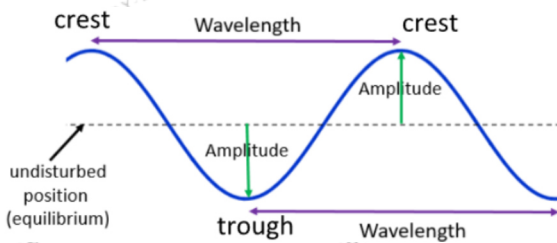

$$v = f \lambda$$

Speed = frequency x wavelength

Transverse waves	Longitudinal waves
Direction of vibration is at right angles to the direction of propagation.	Direction of vibration is parallel to the direction of propagation
Transverse waves consists of crest (high point) and trough (low point)	Consist of regions of compression (area where particles are densely packed) and rarefaction (area where particles are lightly packed)
E.g. electromagnetic radiation, water waves and seismic S-waves.	E.g. sound waves, seismic P-waves

Waves can undergo:

- Reflection
- Refraction
- Diffraction

A ripple tank can be used to see reflection, refraction & diffraction.

1. Reflection - a wave encounters an obstacle and is reflected back

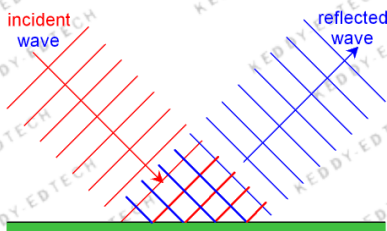

2. Refraction of Waves - As the waves cross the boundary between two different mediums they change speed. Light travels more slowly in water than in air. The frequency of the waves remains unchanged. Waves change their wavelength when their speed changes.

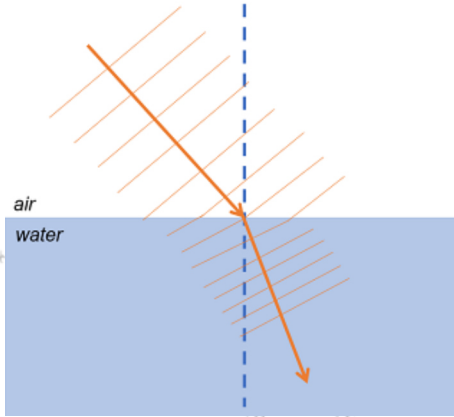

3. Diffraction of Waves - Waves are diffracted when they pass through a gap or around the edge of an obstacle. The effect is greatest (diffracted the most) when the width of the gap is equal or smaller than the wavelength of the ripples.

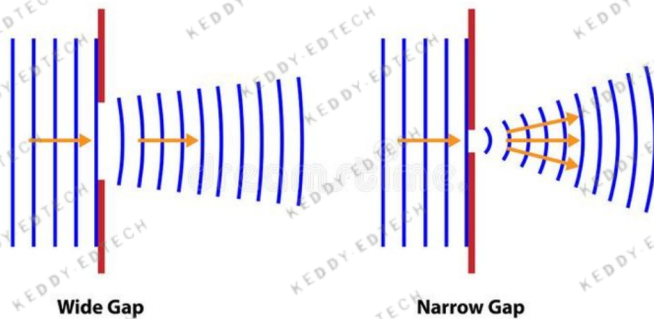

Wavelength - λ of a wave is distance from one crest of the wave to the next. (measured in metres.)

Amplitude - Maximum displacement of a point on a wave away from its undisturbed position.

Frequency - Number of waves per second passing a point. (measured in Hertz, Hz)

Period - Time taken for one complete wave to pass a point. (measured in seconds)

3.2 Light

3.2.1 Reflection of light

Normal ray – The line perpendicular from the reflecting surface at the point of incidence.

Angle of incidence – The angle between the incident ray and the normal.

Angle of reflection – The angle between the reflected ray and the normal.

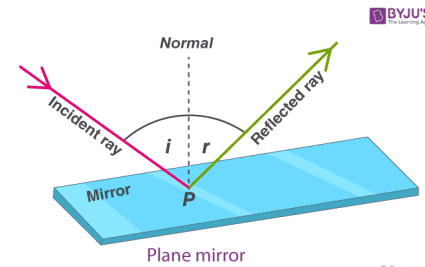

Angle of incidence = angle of reflection.

Characteristics of an optical image: same size, same distance from mirror, virtual.

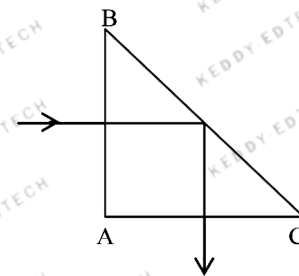
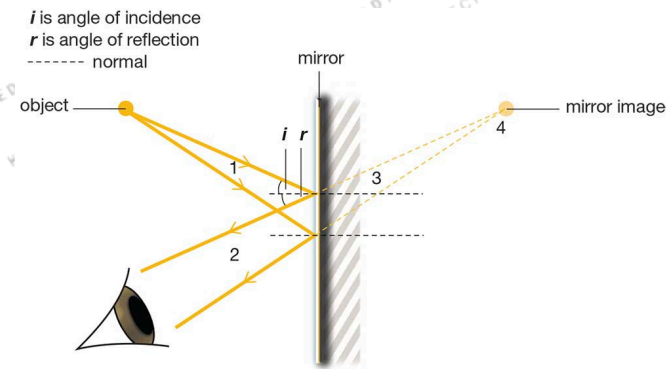

3.2.2 Refraction of light

When light slows down, the ray bends to the normal. When light moves faster, the ray bends away from the normal.

Critical angle – The angle of incidence where the angle of refraction is 90 degrees. This varies from medium to medium

Total internal reflection – The complete reflection of a ray of light from the surrounding surfaces of optically less dense medium back into the denser medium.

Total Internal Reflection

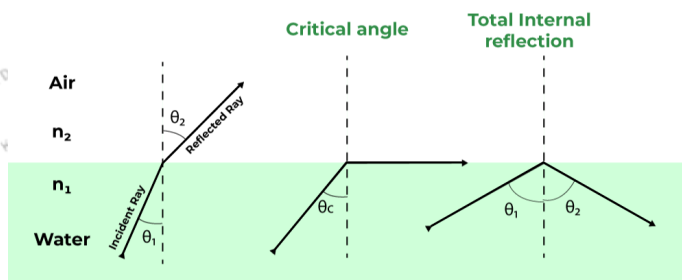

Two conditions for TIR to take place:

1. Light rays must travel from an optically denser medium to a less dense medium.
2. The angle of incidence in optically denser medium > critical angle.

Applications of TIR:

- Prism
- Endoscope
- Optical fibres (flexible, carries more data, has high transmission quality)

Refractive index (n) – The ratio of the speeds of a wave in two different regions.

$$n = \frac{\sin i}{\sin r} \quad n = \frac{1}{\sin c}$$

3.2.3 Thin lenses

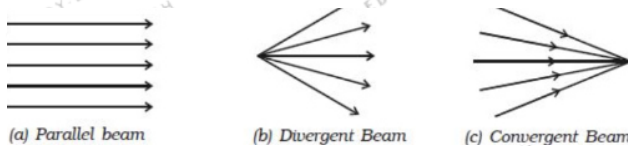

Focal length – Distance from the middle of the lens to F.

Principal axis – The straight line passing the middle of the lens.

Principal focus (focal point) – The point where parallel light rays converge/diverge.

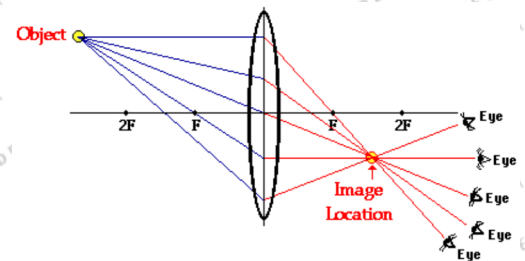

An image can be described as:

1. Inverted or Upright
2. Diminished or Enlarged/Magnified
3. Real or Virtual

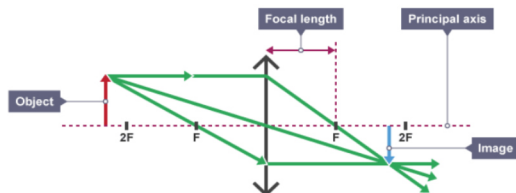

Image is: **inverted, diminished, real.**

E.g. cameras and eyes.

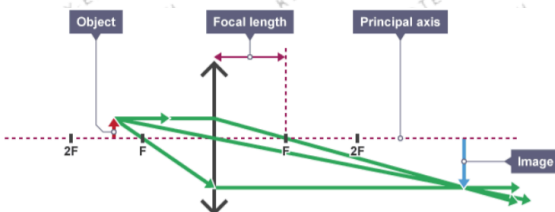

Image is: **inverted, magnified, real**

E.g. projectors.

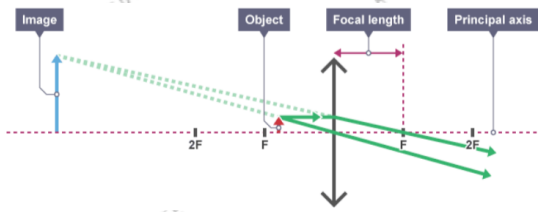

Image is: upright, magnified, virtual
E.g. magnifying glass.

<https://www.bbc.co.uk/bitesize/guides/zgpcqhv/revision/3>

A virtual image is formed when diverging rays are extrapolated backwards and does not form a visible projection on a screen.

To correct long-sightedness, use converging lenses.

To correct short-sightedness, use diverging lenses.

3.2.4 Dispersion of light

Dispersion - process of white light splitting into a spectrum.

Dispersion of Light:

When white light is passed through a glass prism it splits into its spectrum (Band of coloured components of light) of colours (in order red, orange, yellow, green, blue, indigo, violet)

1. White light is made up of many different wavelengths, each wavelength corresponding to a different colour.
2. Each beam of light is slowed differently by the glass.
3. Violet light -> shorter wavelength -> slowed more.
4. When light travels from one medium to another, the speed of its propagation changes -> it 'bends' or is 'refracted'.

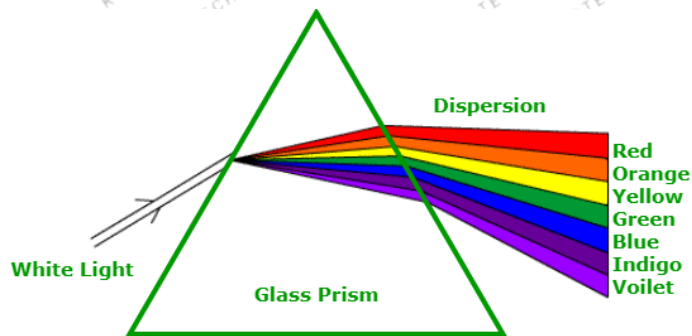

Visible light of a single frequency is described as monochromatic.

3.3 Electromagnetic spectrum

There are 7 types of electromagnetic waves which form the electromagnetic spectrum (EMS).

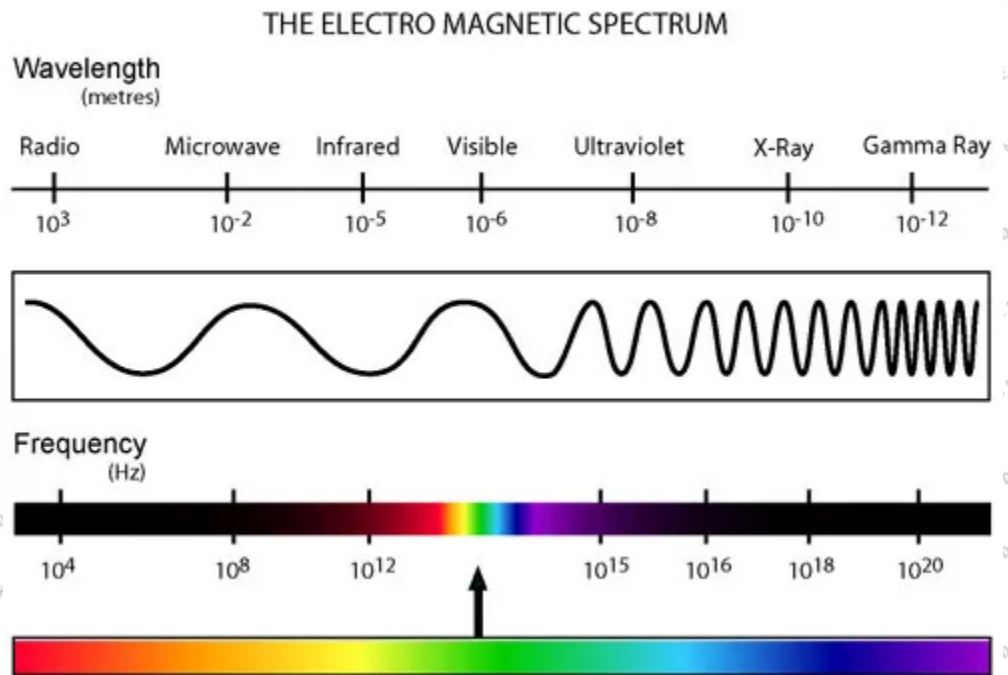

Radio waves have long wavelengths, low frequency & low energy.

Gamma rays have short wavelengths, high frequency & high energy.

All electromagnetic waves travel at the same high speed in a vacuum.

The speed of electromagnetic waves in a vacuum is 3.0×10^8 m/s and is approximately the same in air.

Uses:

Radio waves: radio and television transmissions, astronomy, radio frequency identification (RFID).

Microwaves: satellite television, mobile phones (cell phones), microwave ovens.

Infrared: electric grills, short range communications (such as remote controllers for televisions), intruder alarms, thermal imaging, optical fibres.

Visible light: vision, photography, illumination.

Ultraviolet: security marking, detecting fake bank notes, sterilising water.

X-rays: medical scanning, security scanners.

Gamma rays: sterilising food and medical equipment, detection of cancer and its treatment.

Harmful effects from excessive exposure:

Microwaves: internal heating of body cells.

Infrared: skin burns.

Ultraviolet: damage to surface cells and eyes, leading to skin cancer and eye conditions.

X-rays & gamma rays: mutation or damage to cells in the body.

The higher the frequency, the higher the energy of the radiation.

Radiation with higher energy is:

- Highly ionising.
- Harmful to cells and tissues causing cancer.

Communication with artificial satellites is mainly by microwaves:

- Some satellite phones use low orbit artificial satellites
- Some satellite phones and direct broadcast satellite television use geostationary satellites

Many important systems of communications rely on electromagnetic radiation including:

- Mobile phones (cell phones) and wireless internet use microwaves because microwaves can penetrate some walls and only require a short aerial for transmission and reception.
- Bluetooth uses low energy radio waves or microwaves because they can pass through walls, but the signal gets weakened.
- Optical fibres (visible light or infrared) are used for cable television and high-speed broadband because glass is transparent to visible light and some infrared; visible light and short wavelength infrared can carry high rates of data.

Sound can be transmitted as a digital or analogue signal:

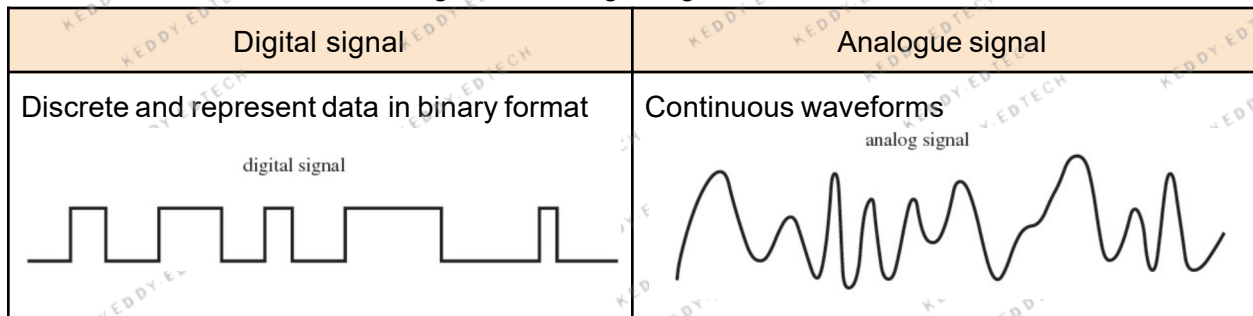

Benefits of digital signalling:

- Increased rate of transmission of data.
- Increased range due to accurate signal regeneration.

3.4 Sound

Sounds are caused by vibrating sources. Vibrating sources cause the air around them to vibrate, which are passed to our ears where they cause the eardrum to vibrate and we hear sound.

A medium is needed to transmit sound waves. Sound travels faster in solids than in liquids and faster in liquids than in gases. The molecules are closer together, and pass on energy quicker.

Sound waves are longitudinal.

Approximate range of frequencies audible to humans as 20 Hz to 20 000 Hz.

Ultrasound – Sound with a frequency higher than 20 kHz.

Speed of sound in the air is approximately 330–350 m/s.

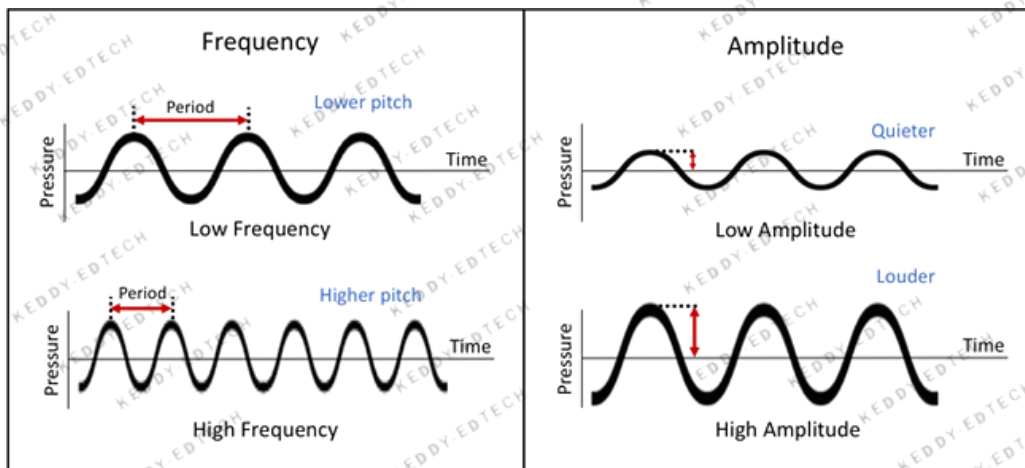

Speed of sound in air = distance ÷ time

Echo – The reflection of sound waves.

Compressions	Rarefactions
Air molecules are compressed together. High air pressure.	Air molecules spread out. Low air pressure.

4 Electricity & magnetism

4.1 Simple phenomena of magnetism

There are two magnetic poles: north & south.

Like poles repel, unlike poles attract.

Magnets and magnetic material are influenced by magnetic fields.

Induced magnetism:

1. When magnetic material is placed in a magnetic field, the material can temporarily be turned into a magnet.
2. The magnet induces magnetism in them.
3. The induced pole of the magnetic material that is closer to the magnet is the opposite of the pole at the end of the magnet.

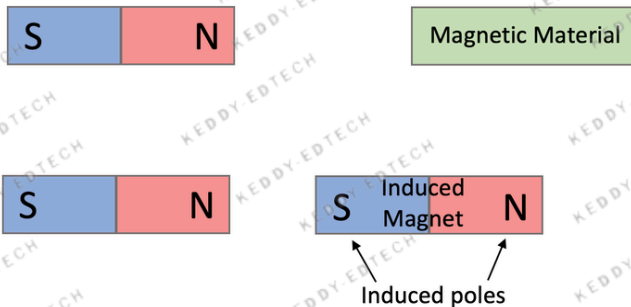

Temporary magnets	Permanent magnets
Only have magnetic field temporarily Made of soft iron	Produce their magnetic field all the time Made of steel

Magnetic Material	Nonmagnetic materials
Any object that can be influenced by magnetic fields, and has the potential to become a magnet.	Any object that cannot be influenced by magnetic fields.

Magnetic field – A region in which a magnetic pole experiences a force.

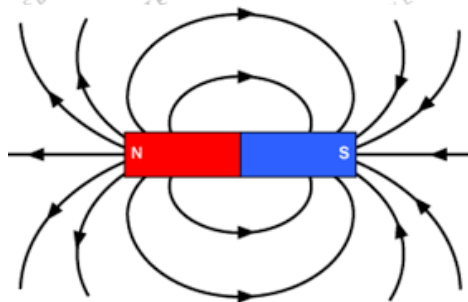

Direction of a magnetic field at a point – The direction of the force on the N pole of a magnet at that point.

Ways of plotting magnetic field lines:

1. With a compass. A compass can determine the direction of the magnetic field.
2. Iron filings.

Permanent magnets	Electromagnets
They stay magnetised.	A type of magnet in which the magnetic field is produced by an electric current.
They cannot be switched on and off.	They can be switched on and off.
Compasses, headphones, loudspeakers.	Electromagnetic cranes, electric bells.

Magnetic forces are due to interactions between magnetic fields.

The relative strength of a magnetic field is represented by the spacing of the magnetic field lines. The closer the lines, the stronger the magnetic field.

4.2 Electrical quantities

4.2.1 Electric charge

There are positive and negative charges.
Positive charges repel other positive charges.
Negative charges repel other negative charges.
Positive charges attract negative charges.

Like charges repel, Opposing charges attract

Electrostatic charges by friction:

When insulating materials rub against each other, they may become electrically charged. Electrons may be 'rubbed off' one material and on to the other. The material that gains electrons becomes negatively charged. The material that loses electrons is left with a positive charge.

Charging of solids by friction involves only a transfer of negative charge (electrons), protons do not move.

Conductors	Insulators
Materials that allow electrical current to flow through them easily.	Materials that don't allow electrical current to flow through them easily.
Have freely moving electrons.	No freely moving electrons.
Metals.	Glass, plastic, rubber, air, and wood.

Charge is measured in coulombs.

Electric field – A region in which an electric charge experiences a force.

Direction of an electric field at a point – The direction of the force on a positive charge at that point.

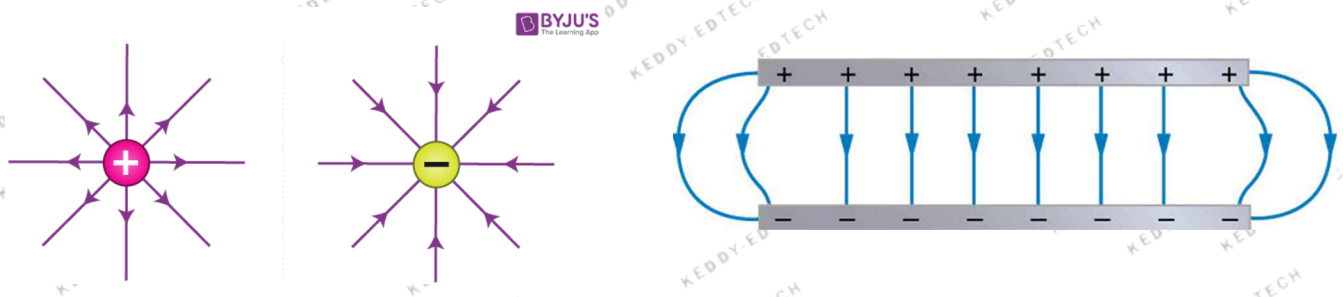

4.2.2 Electric current

Electric current is related to the flow of charge.

Current is measured using an ammeter. They should always be connected in series with the part of the circuit you are measuring the current through.

Analogue ammeters - Typical ranges are 0.1-1A and 1-5A.

Digital ammeters - Can measure very small currents, in mA or μA .

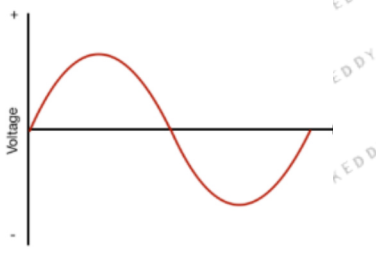
Direct current (d.c.)	Alternating current (a.c.)
The current flows in one constant direction. Produced when using dry cells and batteries.	The electric current changes its direction. Comes from mains electricity and generators.
	

Electric current – The charge passing a point per unit time.

$$I = \frac{Q}{t}$$

Conventional current is from positive to negative.

The flow of free electrons is from negative to positive.

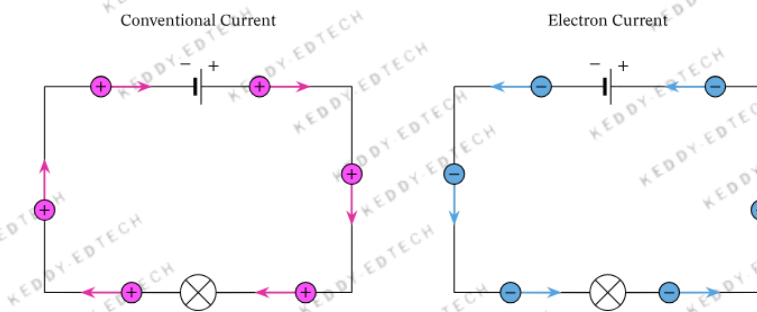

4.2.3 Electromotive force and potential difference

Electromotive force (e.m.f.) – The electrical work done by a source in moving a unit charge around a complete circuit. It is measured in volts (V).

Potential difference (p.d.) – The work done by a unit charge passing through a component. It is measured in volts (V).

Voltage is measured using a voltmeter. They are connected in parallel across a component, to measure the potential difference across the component.

Analogue voltmeters - Typical ranges are 0.1-1A and 1-5A.

Digital voltmeters - Can measure very small currents, in mA or μA .

$$E = \frac{W}{Q} \quad V = \frac{W}{Q}$$

4.2.4 Resistance

$$R = \frac{V}{I}$$

Factors That Affect Resistance:

- Material - Conductors have low resistance.
- Width - Wide wires have less resistance than a narrow wire.
- Length - A longer wire has more resistance than a shorter wire.
- Temperature - Cooler wire has less resistance than a warmer wire.

Filament Lamp	Diode
The more energy that is put into the bulb, resistance increases. As the voltage increases, temperature of the thin wire inside the filament increases.	Diodes force the current in a circuit to flow in only one direction. Current is not proportional to the voltage in a diode. If the voltage is reversed, the resistance increases to prevent current from flowing in the other direction.

A resistor at constant temperature.

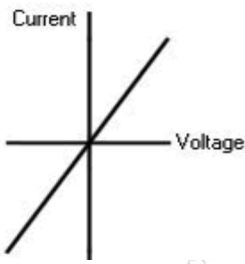

A filament lamp.

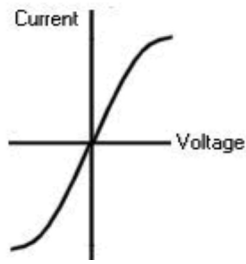

A diode.

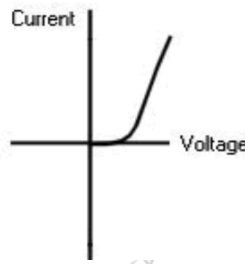

4.2.5 Electrical energy and electrical power

Electric circuits transfer energy from a source of electrical energy, such as an electrical cell or mains supply, to the circuit components and then into the surroundings.

$$P = IV$$

Power = Current x Voltage

$$E = VIt$$

Energy = voltage x current x time

4.3 Electric circuits

4.3.1 Circuit diagrams and circuit components

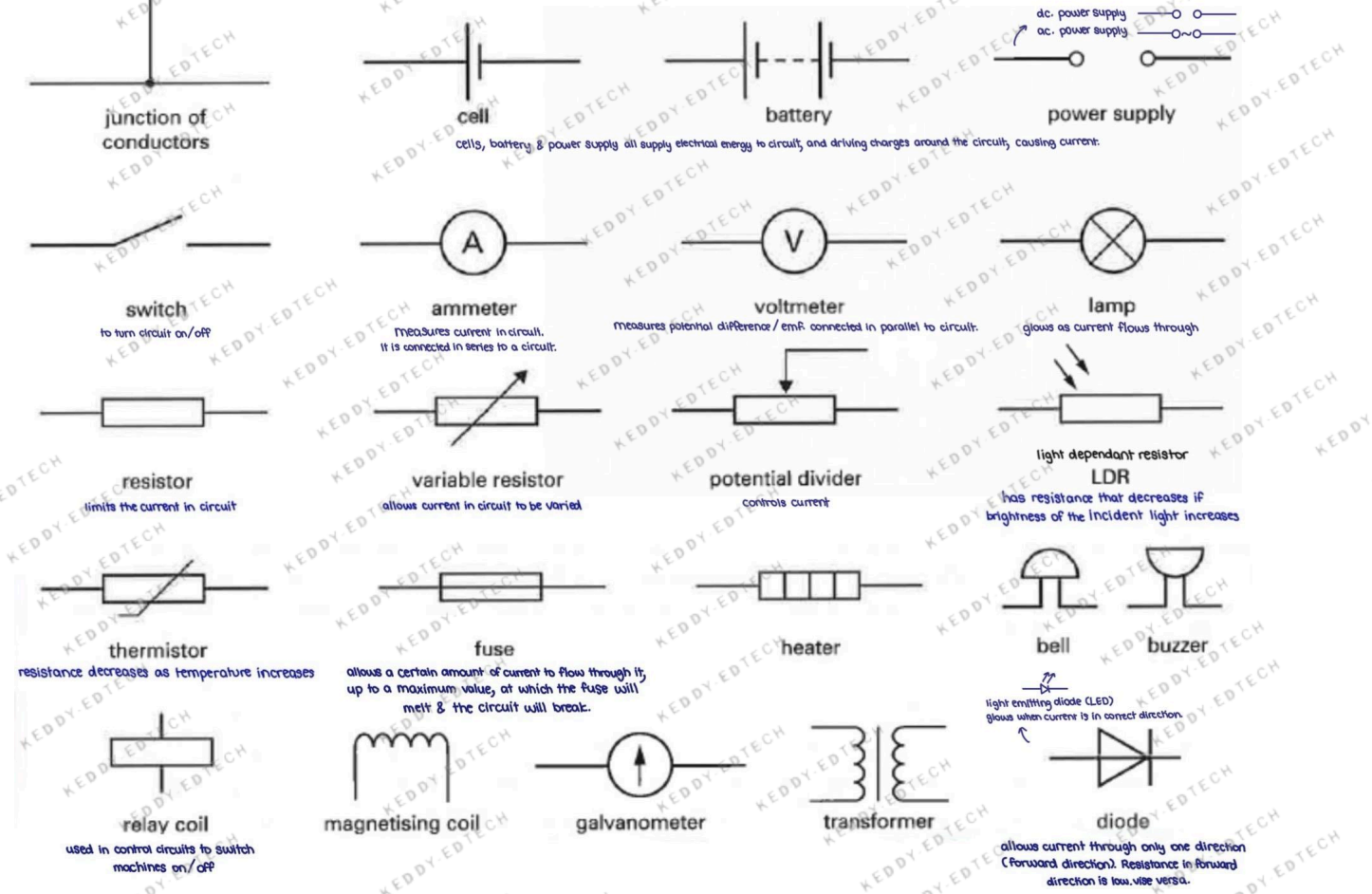

4.3.2 Series and parallel circuits

	Series	Parallel
How it looks		
Voltage	$V_{in} = V_1 + V_2 + V_3$	$V_{in} = V_1 = V_2 = V_3$
Current	$I_{series} = I_1 = I_2 = I_3$	$I_{in} = I_1 + I_2 + I_3$
Resistance	$R_{eq} = R_1 + R_2 + R_3$	$\frac{1}{R_{eq}} = \frac{1}{R_1} + \frac{1}{R_2} + \frac{1}{R_3}$
Features	If one components burns current becomes inactive	If one component burns current stops only through that branch rest part works fine

Voltage in a parallel circuit is equal across components
Current in a series circuit is equal across components

4.3.3 Action and use of circuit components

The p.d. across an electrical conductor increases as its resistance increases for a constant current.

Potential Divider– Part of a circuit consisting of two resistors connected in series to obtain a smaller voltage than supplied.

- The input voltage is applied to the top & bottom of the series resistors.
- The output voltage is measured from the centre to the bottom of R_2 .
- The resistor with more resistance will have greater p.d.

$$\frac{R_1}{R_2} = \frac{V_1}{V_2}$$

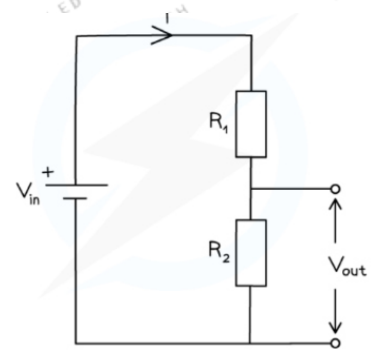

4.4 Electrical safety

Hazards when using a mains supply:

- Damaged insulation
 - When insulation is damaged, conductors and wires could be exposed. Contact with this leads to electric shocks, and deaths.
- Overheating cables
 - Because of the high current, it could cause overheating, leading to electrical fires.
- Damp conditions
 - Water is a conductor. When wet skin touches electricity, they would have an electric shock. When in wet conditions, people nearby could get electrocuted.
- Excess current from overloading of plugs, extension leads, single and multiple sockets

A mains circuit consists of a live wire (line wire), a neutral wire and an earth wire. A switch must be connected to the live wire for the circuit to be switched off safely. This ensures no current flows through the appliance.

Fuses:

- Use: A fuse protects the components in a circuit from overheating.
- Operation: Fuses allow a certain amount of current to flow through it. When it reaches its maximum value, the fuse will melt and the circuit will break.
- Appropriate fuse ratings: Around 5A.

Trip switches

- Use: When the current is too high or when there is a fault in the wiring, it turns off the circuit to stop current from flowing.

The outer casing of an electrical appliance must be non-conducting (double-insulated) or earthed.

- Double insulation is an additional barrier on an electrical device.
- Earthing (via earth wire) allows any leakage of electric current to be transferred to the ground.

They both prevent electrical shocks.

A fuse without an earth wire protects the circuit and the cabling for a double-insulated appliance.

4.5 Electromagnetic effects

4.5.1 Electromagnetic induction

A conductor moving across a magnetic field or a changing magnetic field linking with a conductor can induce an e.m.f. in the conductor.

Electromagnetic induction – Magnetic fields can be used to produce an electric current.

Galvanometer—Used to show the intensity and direction of a current

Practical: Moving wire

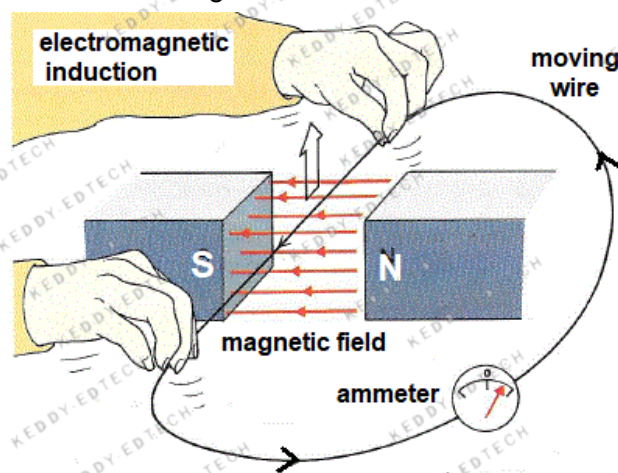

Observations

1. When the wire is moved downwards, the galvanometer deflects to one side briefly and returns to the centre.
2. When the wire is moved upwards, the galvanometer deflects to the opposite side briefly.
3. If the wire is moved sideways there is no deflection on the galvanometer.
4. If the wire is kept stationary in between the poles of the magnet, there is no deflection.
5. If the wire is moved up or down faster, a greater deflection is observed.

Conclusions

1. A current is only induced in the wire when the wire cuts across the magnetic field lines of the magnet.
2. If the wire moves parallel to the field lines (if it doesn't cut them), no current is induced.
3. If the wire is not moving there is no current that is induced in the wire.
4. Increasing the speed of the wire increases the amount of current that is induced.

Practical: Bar magnet & coil

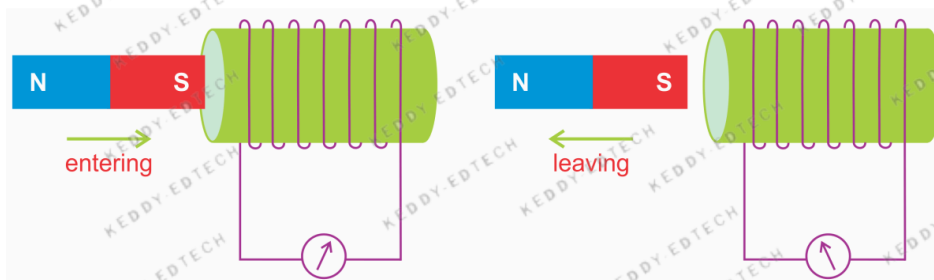

Observations

1. When the magnet is pushed into the coil, the galvanometer deflects to one side briefly and returns to the centre.
2. When the magnet is pulled out of the coil, the galvanometer deflects to the opposite side.
3. If the magnet is held stationary inside the coil, there is no deflection on the galvanometer.
4. If the magnet is moved in or out faster, a greater deflection is observed.

Conclusions

1. A current is only induced in the coil when the field lines of the magnet cut across the wires of the coil.
2. If the magnet is not moving there is no current induced in the wire.
3. Increasing the speed of the magnet increases the amount of induced current.

Increase induced current:

- Move magnet faster
- Adding more turns to coil
- Increasing strength of magnet.

4.5.2 The a.c. generator

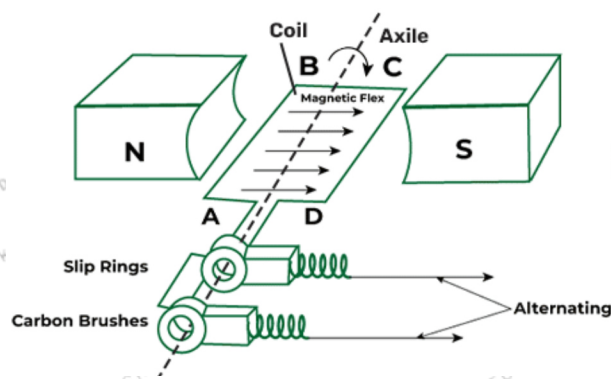

A.c. generator consists of a coil of wire rotating in a magnetic field. It is used in power stations in the large-scale generation of electricity to supply homes and factories.

Consists of:

Slip rings – transfers power between the rotating and stationary structure of an AC machine.

Brushes – makes continuous contact between the external circuit and slip rings.

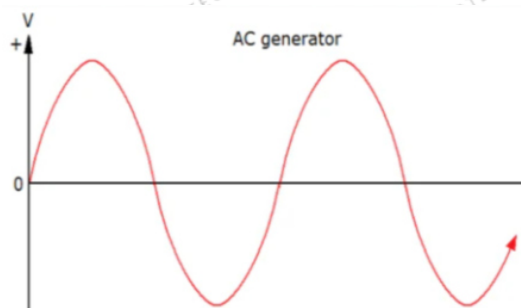

To find direction of current, force and magnetic field, use Flemmings right hand rule.

4.5.3 Magnetic effect of a current

Solenoid (a coil of wire)	Straight wire
<p>The field lines are close together at the poles of the electromagnet Further from the coil, the weaker the field. Inside the coil, the field lines run parallel to each other showing that the field is uniform. Increasing the current gives a stronger field. The polarity of the field is reversed when the current is reversed.</p>	<p>The field lines are circles around the wire. Further away from the wire, the weaker is the field. If the current is greater, the field will be stronger (lines will be closer together) Reversing the current, reverses the direction of the field.</p>

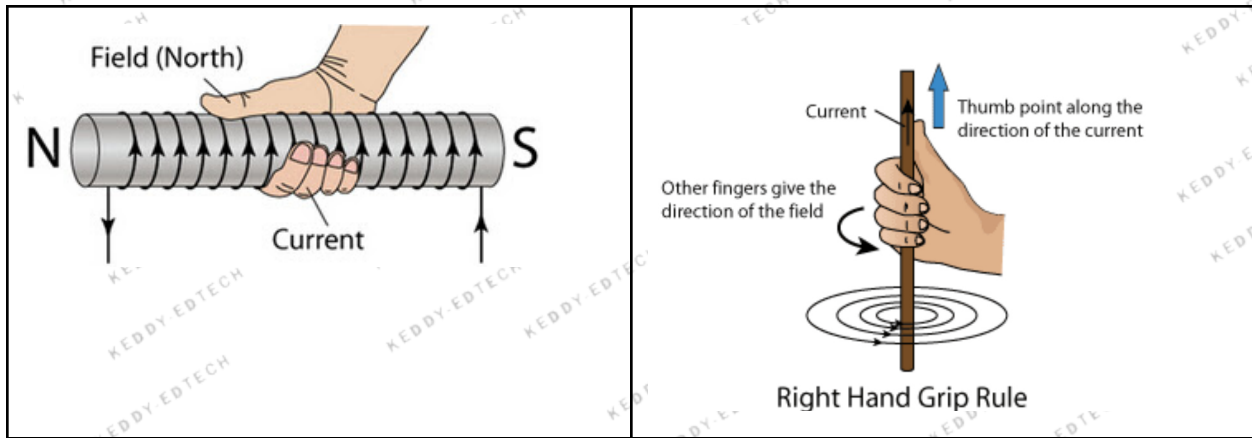

Relay

1. A relay uses an electromagnet and consists of 2 circuits.
2. Input circuit is a simple electromagnet, which requires a small current.
3. When the switch is closed, current flows and the coil becomes an electromagnet.
4. The coil attracts the steel switch in output circuit, closing the switch.
5. Large current flows in the output circuit to operate powerful motor.

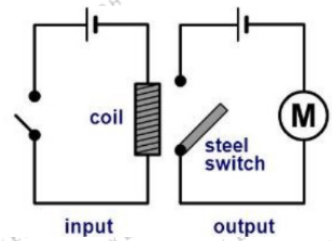

Examples of relay: Ignition key to start a car, TV remote.

4.5.4 Force on a current-carrying conductor

If the current-carrying wire is placed in a magnetic field (whose lines of force are at right angles to wire) then it will experience a force at right angles to both the current direction & magnetic field line.

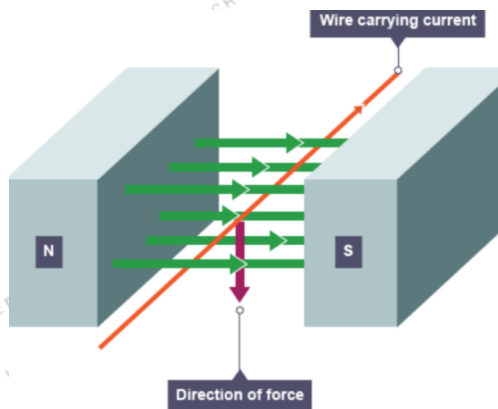

Charged Particle in Magnetic Field

1. A charged particle experiences a force when moving through a magnetic field.
2. If the field is in a vacuum, the magnetic field determines the motion.
3. Since the magnetic force is perpendicular to the direction of travel, a charged particle follows a curved path in a magnetic field.

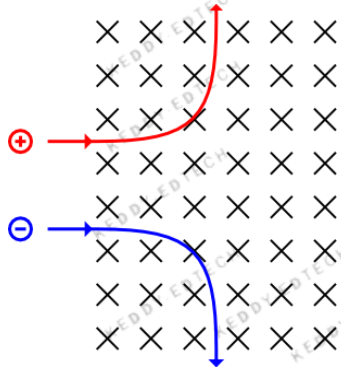

4.5.5 The d.c. motor

A current-carrying coil in a magnetic field may experience a turning effect.

The turning effect can increase by:

- Increasing number of turns on the coil
- Increasing the current
- Increasing the strength of the magnetic field

Electric motor – device transforming electrical energy into mechanical (kinetic) energy.

1. A simple electric motor is built so that a coil of wire connected to an electric circuit is free to rotate between two opposite magnetic poles.
2. When electric current flows, one side of the coil experiences downward force, and the other side of the coil experiences upward force.
3. The wire starts to rotate counterclockwise.
4. To make the rotation continuous, the commutator changes the direction of current flow every half rotation.

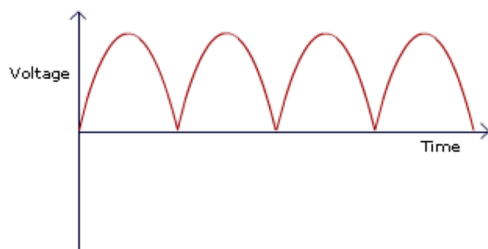

Split ring commutator - swaps the contacts of the coil

- This reverses the direction in which the current is flowing every half turn.
- This will keep the coil rotating continuously as long as the current is flowing.

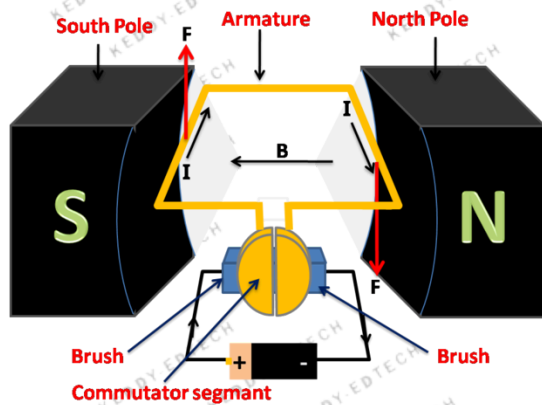

Brushes – makes continuous contact between the external circuit and slip rings.

To find direction of current, force and magnetic field, use Flemmings left hand rule.

4.5.6 The transformer

A simple transformer is used for voltage transformations.

Structure of transformers:

- Iron core, 2 coils of wire:
 - Primary coil from the a.c. input
 - Secondary coil leading to the a.c. output.

Step-up transformer	Step-down transformer
Increases the p.d. for power line transmission	Decreases the p.d. (voltage) of the power line transmission.

$$\frac{V_p}{V_s} = \frac{N_p}{N_s}$$

Where V = voltage and N = number of turns on the coil

How transformers work:

1. Alternating current will create change in magnetic field.
2. Iron core will transfer magnetic field to secondary coil.
3. Magnetic field cuts the secondary coil.
4. E.m.f. of current will be induced.

Transformers are used in high-voltage transmission of electricity.

Why High Voltage:

1. Increase efficiency. As electricity is transmitted over long distances, energy is lost along the way.
2. High voltage transmission minimises power loss.
3. The higher the voltage, the lower the current. The lower the current, the lower the resistance losses in the conductors. And when resistance losses are low, energy losses are low also.

$$I_p V_p = I_s V_s \quad P = I^2 R$$

5 Nuclear physics

5.1 The nuclear model of the atom

Structure of an atom:

- Positively charged nucleus, containing neutrons & protons.
- Negatively charged electrons in orbit around the nucleus.

Atoms may form positive ions by losing electrons or form negative ions by gaining electrons.

Gold foil experiment:

What happened	Conclusion	
Most of the alpha particles passed straight through the foil.	A very small nucleus surrounded by mostly empty space.	
Some alpha particles came straight back off the foil.	Nucleus containing most of the mass of the atom.	
Some alpha particles were deflected.	A nucleus that is positively charged.	

	Relative charge
Proton	+1
Neutron	0
Electron	-1

Proton number (atomic number) – total number of protons

Nucleon number (mass number) – total number of protons + neutrons

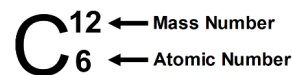

Isotope – Forms of an element that have the same number of protons but different numbers of neutrons.

An element may have more than one isotope.

Fission – The splitting of nuclei

Fusion – The joining of nuclei

5.2 Radioactivity

5.2.1 Detection of radioactivity

Background radiation – Radiation that is present all around us, in natural and artificial sources.

Natural sources:

- Cosmic rays - radiation that reaches the Earth from space
- Rocks and soil - some rocks are radioactive and give off radioactive radon gas
- Food & drink
- Radon gas

Ionising nuclear radiation can be measured using a detector connected to a counter.

5.2.2 The three types of nuclear emission

Nuclear emissions are spontaneous and random in direction. Types of nuclear emissions:

	Alpha (α)	Beta (β)	Gamma (γ)
Their nature	2 protons & 2 neutrons	Electrons	Electromagnetic waves
Ionising power	High	Low	Very low
Penetration	Skin/paper	3mm aluminium foil	Lead/concrete

The greater the charge of the radiation, the more ionising it is.

The higher the kinetic energy of the radiation, the more ionising it is.

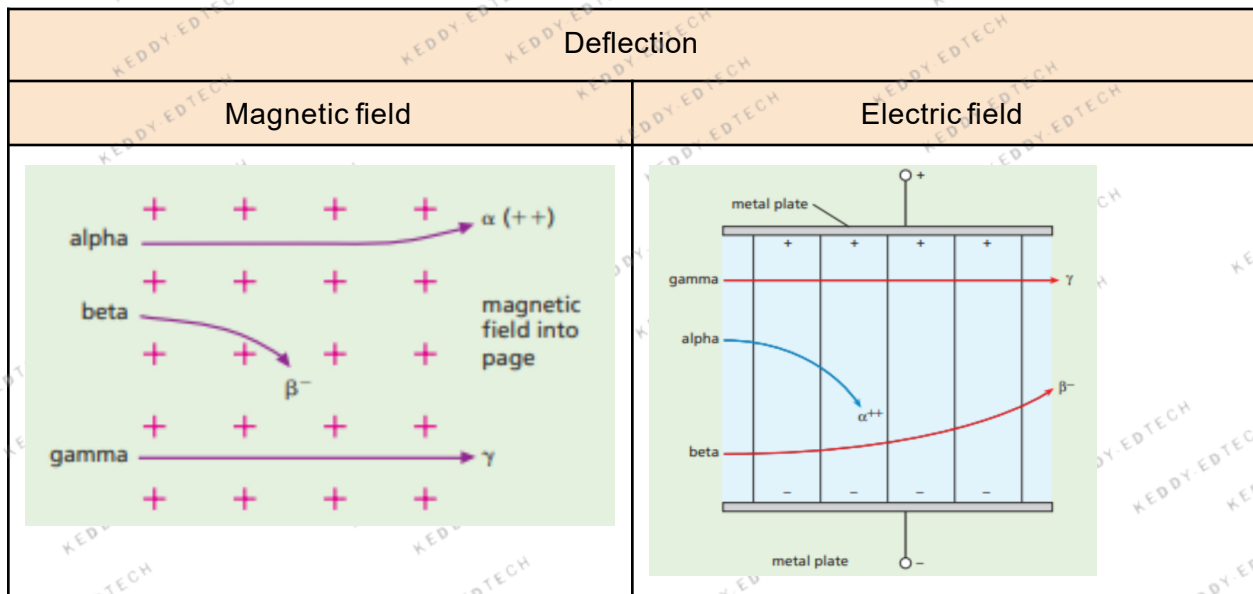

5.2.3 Radioactive decay

Radioactive decay – A change in an unstable nucleus that can result in the emission of α -particles or β -particles and/or γ -radiation. These changes are spontaneous and random.

Radioactive decay - Stable nuclei:

1. An atom's nucleus can only be stable if it has a certain number of neutrons for the protons it has.
2. Elements with excess neutrons in the nucleus or with heavy nucleus, are unstable and will decay, emitting radiation.
3. This helps to reduce their size or bring them back into balance.
4. The constitution of its nucleus changes.
5. The isotope will change into a different element.

	Alpha (α)	Beta (β)	Gamma (γ)
Reactions	${}^A_Z X \longrightarrow {}^{A-4}_{Z-2} X' + \frac{4}{2} \alpha$	${}^A_Z X \longrightarrow {}^{A}_{Z+1} X' + {}^0_{-1} \beta$	${}^A_Z X^* \xrightarrow{\text{Relaxation}} {}^A_Z X' + {}^0_0 \gamma$

5.2.4 Half-life

Half-life of an isotope – The time taken for half the nuclei of that isotope to decay.

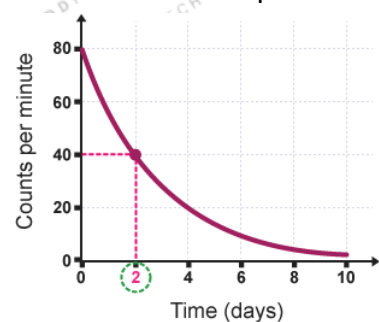

Applications:

- Alpha particles: household fire alarms
- Beta particles: measuring thicknesses of materials
- Gamma rays: irradiating food, sterilisation of equipment, diagnosis & treatment of cancer

5.2.5 Safety precautions

Effects of ionising nuclear radiations on living things: cell death, mutations and cancer.

Safety precautions of ionising radiation

- Reducing exposure time
- Increasing distance between source and living tissue
- Using shielding to absorb radiation

6 Space physics

6.1 Earth & the solar system

The Earth's Axis

- The Earth rotates in a circular orbit around the Sun.
- It rotates on its axis, which is tilted (23.4°)
- One full rotation (revolution) is in 24 hours.
- This rotation creates the daily motion of the Sun rising/setting, and is responsible for the periodic cycle of day and night.

The Earth orbits the Sun once in approximately 365 days. The orbiting of the Earth around the Sun and the Earth's tilt creates the seasons.

It takes approximately one month for the Moon to orbit the Earth. Moon's cycle of phases:

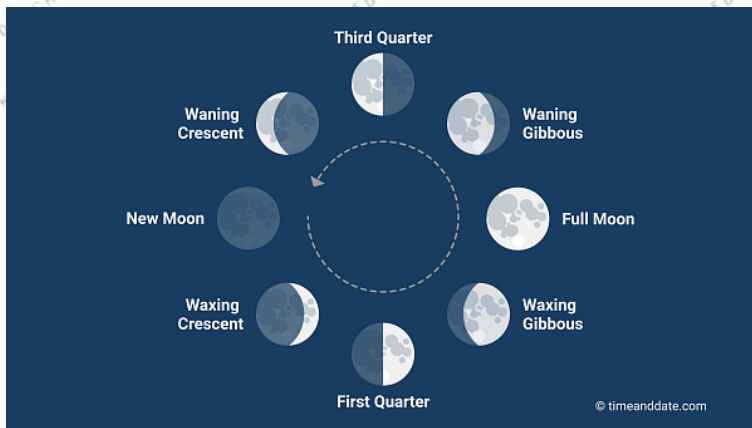

$$v = 2\pi r \div t$$

Orbital speed = $2\pi \times$ average radius of the orbit \div orbital period

Solar System contains:

- One star, the Sun
- Eight planets
- Minor planets that orbit the Sun (dwarf planets & asteroids in the asteroid belt)
- Moons, that orbit the planets
- Smaller Solar System bodies (comets and natural satellites)

Accretion model for Solar System formation:

- The Sun formed when gravitational attraction pulled together clouds of hydrogen dust and gas (called nebulae).
- Planets formed from the remnants of the disc cloud of leftover matter from the nebula.

- These interstellar clouds of gas and dust included many elements that were created during the final stages of a star's lifecycle (a previous supernova).
- Gravity collapsed the matter from the nebula in on itself causing it to spin around the Sun.
- The gravitational attraction between all the small particles caused them to join together and grow in an accretion process.
- A rotating accretion disc is formed when the planets emerge.

Why are the four planets nearest the Sun rocky and small?

- The larger, more heavier elements (such as the metals) are pulled closer to the sun as a result of gravitational force
- As these elements move closer to each other, under great pressure do they form planets

Why are the four planets farthest from the Sun gaseous and large?

- The lighter elements (gases) are left further away from the sun following the creation of these rocky planets
- These large masses of gas form larger, but less dense, gas giants.

Gravitational field strength

- The greater the mass of the planet, the greater its gravitational field strength.
- On the surface of the planet, gravitational field strength is roughly the same.
- Gravitational field strength decreases as the distance from the planet increases.

Orbiting

- The Sun contains most of the mass of the Solar System (99%).
- A smaller body will orbit a larger body.
- Planets will orbit the sun.
- The force that keeps an object in orbit around the Sun is the gravitational attraction of the Sun

Planets, minor planets and comets have elliptical orbits.

The Sun is not at the centre of the elliptical orbit, except when the orbit is approximately circular.

As the distance from the Sun increases: the Sun's gravitational field strength decreases & the orbital speed of the planet decreases.

Orbits & Conservation of Energy

- An object in an elliptical orbit around the Sun travels at a different speed, depending on its distance from the Sun.
- These orbits are not circular, but still stable.
- The radius must change if the comet's orbital speed changes.

- As the comet approaches the Sun: radius of the orbit decreases, orbital speed increases
- Energy must still be conserved, but GPE & KE of the comet changes.
- As the comet approaches the Sun: loses GPE & gains KE \rightarrow comet speeds up \rightarrow slingshot effect \rightarrow the body will be flung back into space again \rightarrow passed around the Sun

6.2 Stars & the universe

Sun

- Medium sized star, consisting of hydrogen and helium
- It radiates most of its energy in the infrared, visible and ultraviolet regions of the electromagnetic spectrum

Stars

- Powered by nuclear reactions that release energy.
- In stable stars, nuclear reactions involve the fusion of hydrogen into helium.

Galaxies:

- Made up of many billions of stars.
- The Sun is a star in the galaxy known as the Milky Way.
- Other stars that make up the Milky Way are much further away from the Earth than the Sun.
- Astronomical distances can be measured in light-years, where one light-year is the distance travelled in space by light in one year. One light-year is equal to 9.5×10^{15} m.

Life cycle of a star:

1. A star is formed from interstellar clouds of gas and dust that contain hydrogen.
2. A protostar is an interstellar cloud collapsing and increasing in temperature as a result of its internal gravitational attraction.
3. A protostar becomes a stable star when the inward force of gravitational attraction is balanced by an outward force due to the high temperature in the centre of the star.
4. All stars will run out of hydrogen as fuel for the nuclear reaction.
5. Most stars expand to form red giant. Bigger stars expand to form red supergiants when most of the hydrogen in the centre of the star has been converted to helium.
6. A red giant forms a planetary nebula with a white dwarf star at its centre.
7. A red supergiant explodes as a supernova, forming a nebula containing hydrogen and new heavier elements, leaving behind a neutron star or a black hole at its centre.
8. The nebula from a supernova may form new stars with orbiting planets.

The Milky Way is one of many billions of galaxies making up the Universe. The diameter of the Milky Way is approximately 100000 light-years.

Redshift - an increase in observed wavelength of electromagnetic radiation emitted from receding stars and galaxies.

The light emitted from distant galaxies appears redshifted in comparison with light emitted on the Earth. Redshift in the light from distant galaxies is evidence that the Universe is expanding and supports the Big Bang Theory.

Microwave radiation of a specific frequency is observed at all points in space around us and is known as cosmic microwave background radiation (CMBR). CMBR was produced shortly after the Universe was formed. This radiation has been expanded into the microwave region of the electromagnetic spectrum as the Universe expanded.

The speed at which a galaxy is moving away from the Earth can be found from the change in wavelength of the galaxy's starlight due to redshift.

The distance of a far galaxy can be determined using the brightness of a supernova in that galaxy.

The Hubble constant H_0 is the ratio of the speed the galaxy is moving away from the earth to its distance from the earth.

The current estimate for H_0 is 2.2×10^{-18} per second.

$$H_0 = \frac{v}{d}$$

$\frac{d}{v} = \frac{1}{H_0}$ Represents an estimate for the age of the Universe and that this is evidence for the idea that all matter in the Universe was present at a single point.

<https://keddy-edtech.org/>